

EDGE E

ENT Examination/ Surgery Chair



 EDGE SURGICAL SOLUTIONS

Registered Community Design

WHO WE ARE | QUI NOUS SOMMES | CHI SIAMO

THE COMPANY

EDGE SURGICAL SOLUTIONS is specialized in developing and manufacturing Multispecialty Examination and Surgery Chairs, Surgeon's Stools and Furniture.

EDGE SURGICAL SOLUTIONS is committed to the continuous research of innovative technical solutions for the Professionals; the range of equipment offered is based on and follows rigid guidelines: latest technology, perfect work-flow ergonomics, reliability, design and highly intuitive and easy to operate by the Professional.

The Company is directly involved through all development, manufacturing, assembly and quality control, shipment, installation and after-sale service phases thanks to its vast network of Distributors and Agents.

In the Company premises there is a permanent Show-Room and a Training Area for theory-practice sessions.

A well structured company organization that has enabled EDGE SURGICAL SOLUTIONS to grow at national and international level keeping the highest quality standards and constant innovation of its range of products.

ENTREPRISE

EDGE SURGICAL SOLUTIONS est spécialisée dans la conception et la fabrication de Fauteuils Polivalents et pour la Chirurgie Ambulatoire, Siège Praticien et Meubles.

EDGE SURGICAL SOLUTIONS est engagée dans la recherche constante de solutions innovantes pour les opérateurs professionnels; la gamme qu'elle propose suit des directives très précises: ergonomie, fiabilité, design et une simple utilisation pour les opérateurs.

La Société est directement impliquée dans chaque phases de conception et de développement de ses produits, à partir de la production et l'assemblage, au contrôle, jusqu'à l'expédition et la distribution, offrant un support technique et commercial complet et compétent. Tout cela grâce à un réseau coordonné et capillaire reliant ses agents et ses partenaires-distributeurs et grâce à son service après-vente interne.

A l'intérieur de son établissement, EDGE SURGICAL SOLUTIONS propose une salle d'exposition permanente et une salle de formation pour l'entraînement théorique et pratique.

Une organisation qui nous a permis de nous développer au bout des années sur le marché Nationale et Internationale, toujours en gardant les plus hauts standards de qualité et un renouvellement constant de notre gamme de produits.



“All EDGE SURGICAL SOLUTIONS Medical Equipment is designed, developed and manufactured in Italy”

L'AZIENDA

EDGE SURGICAL SOLUTIONS è specializzata nella progettazione e nella fabbricazione di Poltrone Chirurgiche Multispecialistiche, Seggiolini Chirurgici e Arredi.

EDGE SURGICAL SOLUTIONS è impegnata nella continua ricerca di soluzioni innovative per gli Operatori professionali; la gamma che propone si basa su linee guida molto rigide: ergonomia, affidabilità, design e massima semplicità di utilizzo per gli Operatori.

L'Azienda è direttamente coinvolta in tutte le fasi di progettazione e sviluppo, produzione e assemblaggio, controllo, spedizione e commercializzazione, offrendo un supporto tecnico e commerciale completo e competente grazie ad una rete capillare di Agenti e Distributori ed un Servizio Assistenza Interno.

Nella sua sede EDGE SURGICAL SOLUTIONS offre uno Show-room permanente ed una Sala Corsi per la Formazione.

Una organizzazione aziendale che ci ha permesso in pochi anni di crescere a livello nazionale ed internazionale mantenendo i più alti standard qualitativi e il rinnovamento costante della gamma prodotti.



HOW WE WORK | COMMENT NOUS TRAVAILLONS | COME LAVORIAMO

R&D

EDGE SURGICAL SOLUTIONS R&D Team develops internally all the equipment and devices for the Professionals and Clinics, always combining modern and essential design to the latest and most innovative technical solutions.

L'équipe EDGE SURGICAL SOLUTIONS Design développe en interne tout équipements dédiés au Professionnel et à la Cabinet, toujours en alliant un design moderne avec les solutions techniques les plus fonctionnelles et innovantes.

Il Team di Progettisti EDGE SURGICAL SOLUTIONS sviluppa internamente tutte le attrezzature dedicate al Professionista e alla Clinica, coniugando sempre con attenzione un design moderno alle soluzioni tecniche e funzionali più innovative.



R&D
R&D
R&D



EDGE SURGICAL SOLUTIONS manufactures a wide and complete range of Surgical Chairs, Doctor Stools and Furniture. Every single production phase is planned and performed according to the most rigid quality control criteria.

EDGE SURGICAL SOLUTIONS réalise sa gamme complète de Fauteuils de Chirurgie, Sièges Praticien et Meubles. Chaque phase de la production est organisée suivant des critères très stricts de qualité et de contrôle.

EDGE SURGICAL SOLUTIONS produce una gamma completa di Poltrone Chirurgiche, Sgabelli e Arredi. Ogni fase produttiva è organizzata secondo rigidi criteri di qualità e controllo.



PRODUCTION
PRODUCTION
REALIZZAZIONE

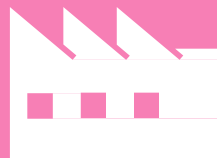

EDGE SURGICAL SOLUTIONS will design your Ambulatory Surgery Center in order to allow for the best work-flow and ergonomics while guaranteeing maximum comfort to the Patient, according to the space availability and your different set up needs as a Professional.

Nous étudions les meilleures solutions de projet pour votre Salle de Chirurgie Ambulatoire, afin de vous garantir une parfaite ergonomie et un maximum de confort, tout en gardant toujours les solutions les plus adaptées à votre espace.

Progettiamo il tuo Ambulatorio Chirurgico per garantirti la migliore ergonomia di lavoro e il massimo comfort proponendo sempre le soluzioni più adeguate al tuo spazio.



PROJECT
PROJET
PROGETTO

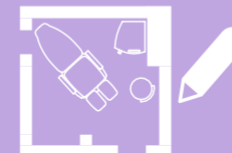

INSTALL
INSTALL
INSTALL



All EDGE SURGICAL SOLUTIONS equipment is "Plug-in & Work" easy to set up and ready to use with very few and easy installation steps. EDGE SURGICAL SOLUTIONS guarantees a highly professional installation service thanks to its vast network of Distributors and Agents, and a product specialist will train the Ambulatory staff on the correct use of the installed equipment.

Tous les équipements EDGE SURGICAL SOLUTIONS sont fabriqués suivant le principe du "Plug-in & Work", facile à installer et avec un service d'expédition et de livraison consolidés. EDGE SURGICAL SOLUTIONS garantit un service professionnel d'installation de votre Cabinet grâce à un réseau de distributeurs impliqués dans chaque phase. Un de nos technico-commerciaux vous garantira une formation complète pour l'utilisation de tout équipements à l'intérieur de votre Cabinet.

Tutte le Attrezzature EDGE SURGICAL SOLUTIONS sono realizzate con il principio del "Plug-in & Work", facili da installare e con un servizio di spedizione e consegna dedicato. EDGE SURGICAL SOLUTIONS garantisce un servizio professionale di allestimento del tuo Ambulatorio grazie ad una vasta rete di Distributori che ne seguono ogni fase. Un nostro product specialist garantirà la formazione in loco sull'utilizzo delle attrezzature installate nel tuo Ambulatorio.



EDGE SURGICAL SOLUTIONS is committed to continuous training and information of all its Customers; the Company can rely on the cooperation with prominent experts in each medical discipline and often involved in training sessions on the specific equipment and different operating methods.

EDGE SURGICAL SOLUTIONS connaît l'importance de promouvoir de l'information et de la formation de tous ses clients, en collaboration avec des experts du secteur et en organisant des sessions de formations dédiées aux équipements et à techniques très spécifiques.

EDGE SURGICAL SOLUTIONS promuove da sempre l'informazione e la formazione dei suoi clienti collaborando con prominenti esperti di settore e organizzando sessioni e corsi di formazione dedicati alle varie e specifiche attrezzature e metodiche operative.



EDGE SURGICAL SOLUTIONS considers Warranty a professional duty and mandatory towards all its Customers, reason being the Company extends guarantee of the equipment up to 2 Years on Electronic Parts and up to 5 Years on Mechanic Parts.

EDGE SURGICAL SOLUTIONS considère la garantie des produits comme un engagement ferme envers tous ses clients. Pour cette raison, la garantie de nos équipements couvre jusqu'à 2 ans pour les composants électroniques et jusqu'à 5 ans tout composants mécaniques.

EDGE SURGICAL SOLUTIONS considera la Garanzia dei prodotti un dovere verso tutti i suoi clienti e per questo garantiamo le nostre attrezzature fino a 2 anni per le componenti elettroniche e fino a 5 anni per tutte le componenti meccaniche.

All Customers can rely on a punctual and qualified after-sale assistance thanks to the in-house Service Department. You will be able to request a Preventive Maintenance and Courtesy Service to our Distributors and avoid any unexpected interruption of your professional activity.

Nos clients peuvent compter sur un SAV rapide et qualifié, grâce à son Département interne. Vous aurez également la possibilité de profiter d'un service de maintenance programmé, ainsi que d'un "Service de Courtoisie" assuré par nos Distributeurs afin d'éviter toute interruption de votre activité professionnelle.

I nostri clienti possono contare su un Servizio di Assistenza puntuale e qualificato grazie al dipartimento Service interno. Avrai la possibilità di richiedere un Servizio di Assistenza Programmata e il Servizio "Cortesia" al Distributore incaricato per non avere mai interruzioni della tua attività professionale.



INSTALLATION
INSTALLAZIONE



TRAINING
FORMATION
FORMAZIONE



WARRANTY
GARANTIE
GARANZIA



SERVICE
SERVICE APRES-VENTE
ASSISTENZA



AMBULATORY SURGERY | CHIRURGIE AMBULATOIRE | CHIRURGIA AMBULATORIALE

A Transformative Model for Modern Surgery and Procedures in ASC and Outpatient Rooms.

Ambulatory Surgery Centers—known as ASCs—are modern health care facilities focused on providing same-day surgical care, including diagnostic and preventive procedures.

ASCs have transformed the outpatient experience for millions of Patients around the World by providing them with a more convenient alternative to hospital-based outpatient procedures—and done so with a strong track record of quality care and positive patient outcomes while proving highly cost-effective.

Forty years ago, virtually all surgery was performed in hospitals; waits of weeks or months for an appointment were not uncommon, and

patients typically spent several days in the hospital and several weeks out of work in recovery. In many countries, surgery is still performed this way, but it is rapidly changing.

Physicians faced with frustrations like scheduling delays, limited operating room availability, slow operating room turnover times, and challenges in obtaining new equipment due to hospital budgets and policies, physicians were looking for a better way—and developed it in ASCs.

EDGE SURGICAL SOLUTIONS has fully committed to give a contribution to the development of technically advanced, elegant and cost-effective equipment that enables Physicians to perform Examinations and Procedures according to the time saving principle of rotation: prepare the Patient, perform Surgery and keep Patient for observation and recovery on the same Chair. When the Physician is

operating, staff can prepare the following Patient for surgery and at the same time the previous Patient is safely and comfortably recovering on the same chair. The Patient is never moved from the chair, access is easily granted thanks to the extremely low entry/exit height of the chair, and then by simply pressing the memory buttons the Patient will immediately reach operating position previously set and memorized by the Physician. The chair turns to an operating table, then to a recovery bed and back to examination chair by simply operating the wireless foot-control, and all of this performed at ease, with maximum comfort for the Patient and best ergonomics for the Physician.

Le Modèle Transformatif pour la Chirurgie Moderne et les traitements de Chirurgie Ambulatoire.

Les centres de Chirurgie Ambulatoire - appelés ASC - sont des centres médicaux modernes spécialisés sur le service de traitement chirurgical en "day surgery" y compris les activités de diagnostic et tout traitements préventifs.

Les ASC ont transformé l'expérience ambulatoire de millions de

Patients dans le monde en garantissant une alternative concrète aux interventions hospitalières et, par conséquent, en obtenant des résultats extrêmement positifs en termes cliniques et économiques.

Il y a 40 ans, quasiment la totalité des traitements chirurgicaux étaient pratiqués au sein de structures hospitalières; longues listes d'attente pour une visite, patients hospitalisés pendant des jours et plusieurs semaines de convalescence étaient à considérer constamment. La chirurgie est toujours garantie de cette façon dans plusieurs Pays à

présent, mais les choses évoluent très rapidement. Les opérateurs professionnels étant frustrés par les rendez-vous tardifs ou la disponibilité limitée des salles de chirurgie, ou bien par des longs délais dans les procédures de rotation à l'intérieur des salles de chirurgie après chaque intervention, ainsi que l'ensemble des difficultés quotidiennes pour obtenir de nouveaux équipements en ces raisons ont conduit les opérateurs professionnels à rechercher de

Modern Surgery and Procedures in ASC and Outpatient Rooms



EASY ACCESS

PATIENT TRANSPORT

PREOPERATIVE PREPARATION

EDGE SURGICAL SOLUTIONS



Registered Community Design

EDGE

ENT Examination/ Surgery Chair

Is EDGE SURGICAL SOLUTIONS concept of ENT Examination and Treatment Chair; it is the result of innovative technical and engineering solutions that enable the ENT Professionals to perform all examinations, treatments and minor procedures in Outpatient Rooms and Ambulatory Surgery Centers. It is the perfect working tool that suits all clinics and private practices in ENT field.

Est le nouveau concept de fauteuil SURGICAL SOLUTIONS, pour l'examen et le traitement ORL. C'est le résultat de solutions techniques et de conception innovantes permettant aux professionnels des Centres ORL d'effectuer tous les examens et tous les traitements. C'est l'outil ultime qui répond aux exigences de toutes les cliniques et les cabinets privés dédiées au domaine ORL.

E' il nuovo e moderno concept ultimate di Poltrona da Visita/ Chirurgia ORL sviluppato e prodotto da EDGE SURGICAL SOLUTIONS. **EDGE** è il risultato di soluzioni tecniche e ingegneristiche innovative che consentono al Professionista di eseguire qualunque esame clinico e/o trattamento in Ambulatorio ORL o Ambulatorio Chirurgico. Rappresenta lo strumento perfetto ed essenziale per l'attività professionale di ogni Otorinolaringoiatra.



EDGE E

It is conceived in a solid structure, painted with epossidic powder and operated with 3 silent linear actuators and one telescopic column by a modern and multifunction foot control. The upholstery comprises 5 separate padded sections fully removable for easy cleaning and disinfection, made of high density undeformable foam and the cover is an abrasion-resistant, flame retardant and antimicrobial Skai available in 46 different colours and 8 textures. It is designed for the comfort of the patient and the ergonomic of the operator, it reaches a minimum height of 51cm (20 inches) and a maximum height of 91cm (36 inches) allowing patients with medical conditions easily access the chair from the front or the sides without any barrier, while allowing the operator to position the chair in a multiple range of heights and inclinations enabling any examination or treatment.

Il est équipé d'une structure métallique solide, peinte avec poudre épossidique et actionnée par 3 actionneurs linéaires et da 3 une colonne télescopique commandés par la pédale multifonction. La sellerie comprend 5 sections rembourrées entièrement détachables pour en faciliter le nettoyage et la désinfection, étant réalisés avec mousse indéformable ad haute densité, résistant à l'abrasion, ignifuge et antimicrobienne et avec une couverture en Skai disponible dans 46 couleurs et 8 textures différentes.

è concepita con una metal solida struttura metallica, verniciata con polveri epossidiche e azionata da 3 attuatori lineari tramite il comando a pedale multifunzione. La tappezzeria comprende 5 sezioni imbottite completamente rimovibili per una facile pulizia e disinfezione, realizzate in schiuma indeformabile ad alta densità e con un rivestimento in Skai resistente all'abrasione, ignifugo e antimicrobico, disponibile in 46 diversi colori ed 8 diverse trame di tessuto. E' progettata per il comfort del paziente e per l'ergonomia dell'operatore. La poltrona raggiunge un'altezza minima di 51 cm e una massima di 91 cm permettendo ai pazienti un accesso facile dal davanti o dal lato senza alcuna barriera.



plug & work



wireless



memory



zero position



disinfection



4motors



80 colours available

Registered Community Design

| code | description |
|-----------|---------------------------|
| 9110502-W | EDGE E (white structure) |
| 9110502-S | EDGE E (silver structure) |

EDGE_E



It is operated by 3 silent linear actuators and one telescopic column that enable the Operator to position the chair at the desired heights and inclinations, reaching the correct medical positioning. Safety is guaranteed by the Anti-Crushing Technology that detects harmful impacts and stops the chair immediately.

Il est actionné par 3 moteurs linéaires silencieux et une colonne télescopique permettant à l'Opérateur de positionner le fauteuil aux hauteurs et inclinaisons souhaitées, atteignant le positionnement médical correct. La sécurité est assurée par la technologie anti-écrasement qui arrête les mouvements du fauteuil en cas d'impact dangereux avec tous obstacles inattendus.

E' dotata di 3 attuatori lineari silenziosi e di una colonna telescopica che consente all'Operatore di posizionare la Poltrona alle altezze e alle inclinazioni desiderate, raggiungendo il corretto posizionamento medico. La sicurezza è garantita dalla Tecnologia Anti-Schiacciamento che interrompe i movimenti della Poltrona in caso di impatto pericoloso con ostacoli imprevisti.

EDGE E



51 cm

The chair reaches a minimum height of 51cm allowing patients with different medical conditions to easily access the chair from the front or the sides without any barrier.

Il atteint une hauteur minimum de 51 cm (20" inches) permettant aux patients souffrant de différentes conditions d'accéder facilement au fauteuil par l'avant ou des côtés, sans aucune barrière.

Raggiunge un'altezza minima di 51 cm consentendo ai pazienti di accedere facilmente dalla parte anteriore o laterale, senza nessuna barriera.



360°

The chair can horizontally rotate 360°. The lever allows the Operator to rotate and stop the rotation of the chair locking the desired position.

Il peut effectuer une rotation de 360°. Le levier permet à l'Opérateur de bloquer la rotation à la position souhaitée.

Può ruotare di 360°. La leva permette all'Operatore di bloccare la rotazione nella posizione desiderata.



130 cm

The chair reaches the height of 130 cm at maximum leg- rest extension.

Le fauteuil atteint la hauteur maximale de 130 cm avec l'axe des jambières allongés.

Raggiunge un'altezza di 130 cm alla massima estensione del gambale.



91 cm

The chair can reach a perfect flat position at any height, for the maximum comfort of the Operator while performing a clinical examination or professional treatment/ procedure. Maximum height 91 cm.

Le fauteuil peut atteindre une position parfaitement plate à n'importe quelle hauteur, pour le maximum de confort pour l'opérateur lors d'un examen ou un traitement professionnel. Hauteur maximum 91 cm.

Raggiunge la posizione lettino a qualsiasi altezza, per il massimo comfort dell'operatore durante l'esecuzione di un esame clinico o un trattamento professionale. Altezza massima 91 cm.

EDGE E



Zero position of the chair.
The chair automatically reaches "0" position to facilitate the access and the exit of the Patient.

*Remise à zéro du fauteuil.
Le fauteuil atteint la position "0" automatiquement pour faciliter l'accès et la descente du Patient .*

Ritorno a zero.
Raggiunge automaticamente la posizione "0" per facilitare l'accesso e l'uscita del paziente.



It allows the operator to perform "Synchro" movements of the Chair enables the combined and synchronized movement of the back-rest and leg-rest.

Il permet à l'Opérateur des mouvements synchronisé du dossier et jambière. par la fonction "Synchro" du Fauteuil.

Consente all'operatore di eseguire movimenti "Synchro" della Poltrona, ovvero il movimento combinato e sincronizzato dello schienale e del gambale.



It can rely on a lifting capacity of 325 kg, one of the highest in its category.

Il est en mesure d'atteindre une capacité de levage de 325 kg, l'une des plus élevée de sa catégorie.

E' in grado di assicurare una capacità di sollevamento di 325 kg, uno dei più alti nella sua categoria.



It reaches Trendelenburg position with 20° inclination.

Il atteint la position Trendelenburg avec une inclinaison de 20 °.

Raggiunge la posizione di Trendelenburg con un'inclinazione di 20 °.

EDGE E



Head-rest is shaped and padded according to the general ENT examination standards. It can be completely removed when necessary.

PROVIDED IN THE STANDARD VERSION

Les appui-têtes sont rembourrés et disponibles suivant les exigences des différents procédures ENT, et peuvent être complètement enlevés si nécessaire.

FURNI DANS LA VERSION STANDARD

Il poggiatesta è sagomato e imbottito in base alle esigenze delle procedure ENT e può essere completamente rimosso quando necessario.

FORNITO NELLA VERSIONE STANDARD



The articulated head-rests are adjustable in 3 directions, can be locked firmly when reaching the correct position of the Patient.

Les appui-têtes articulés sont réglables vers 3 directions, et peuvent être bloqués lorsqu'ils atteignent le positionnement correct du Patient.

I poggiatesta articolati sono regolabili in 3 direzioni, possono essere bloccati saldamente quando si raggiunge la posizione corretta del paziente.

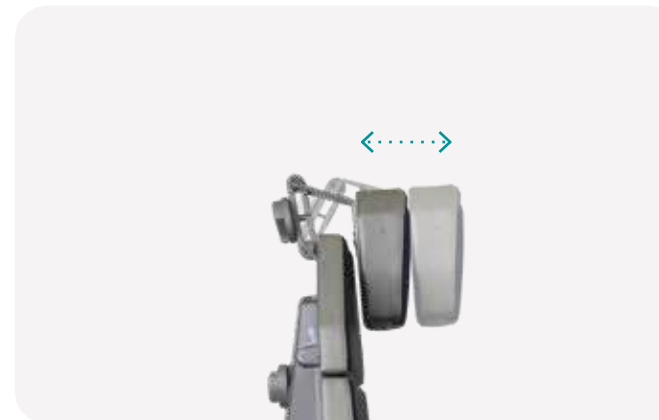
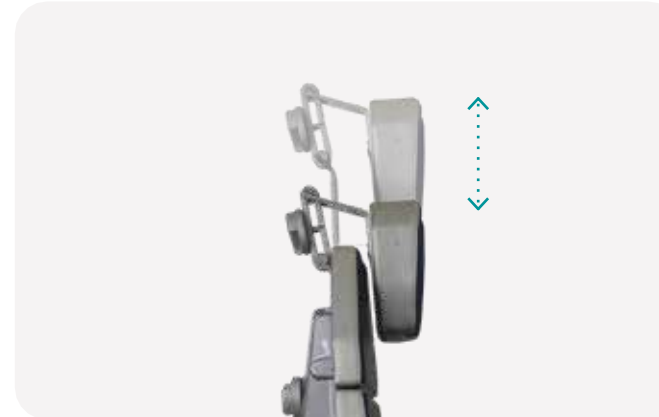

EDGE E



Arm-rest is shaped and padded for the maximum comfort of Patient.

PROVIDED IN THE STANDARD VERSION

Les accoudoirs sont rembourrés et disponibles pour le confort maximum du Patient.

FOURNI DANS LA VERSION STANDARD

I braccioli, interamente imbottiti e realizzati in forma ergonomica per il massimo confort del Paziente.

FORNITO NELLA VERSIONE STANDARD

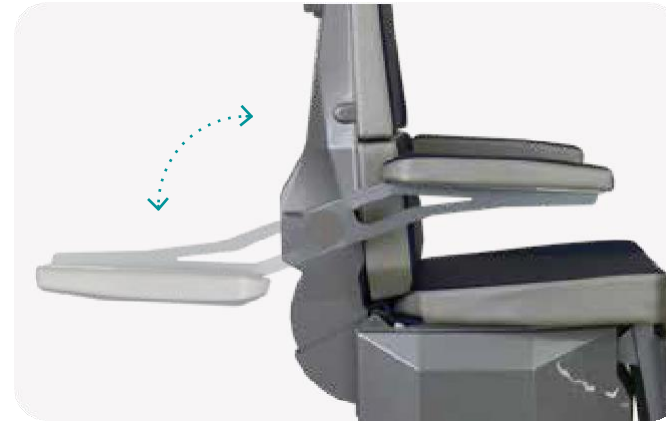

Both padded arm-rest are independently collapsible, removable and mechanically combined with the seat/back-rest movements ensuring comfort for the patient in any position.

Les deux accoudoirs rembourrés sont repliables de manière indépendante, amovibles et combinés mécaniquement avec les mouvements de l'assise et du dossier, garantissant le maximum de confort pour le patient dans toutes les positions.



Entrambi i braccioli imbottiti sono indipendentemente richiudibili, rimovibili e combinati meccanicamente con i movimenti del sedile e dello schienale assicurando comfort per il paziente in qualsiasi posizione.



EDGE E



Padded and shaped leg-rest.
PROVIDED IN THE STANDARD VERSION

Jambière rembourrée actionnée avec une commande au pied multifonction par actionneur linéaire.

FOURNI DANS LA VERSION STANDARD

Gambale imbottito e sagomato.
FORNITO NELLA VERSIONE STANDARD



Leg-rest operated with a multifunction foot control by with a linear actuator.

Jambière rembourrée actionnée avec une commande au pied multifonction par actionneur linéaire.

Il gambale è movimentato elettricamente da un attuatore lineare attivato dal pedale.



Stainless steel retractable foot-rest with a load capacity of 80Kg provides maximum comfort to the Patient.

Le repose-pieds repliable en acier inoxydable, et résistante à une pression de 80kg, fournit au Patient le maximum confort pour tout examen ORL.

Il poggia-piedi in acciaio Inox, resistente ad una pressione fino a 80 Kg, garantisce il massimo comfort al Paziente.



EDGE E



It is provided in the standard version with the structure in White color or Silver at choice.

PROVIDED IN THE STANDARD VERSION

Il est fourni dans la version standard avec la structure en couleur Blanc ou Argent à choix.

FOURNI DANS LA VERSION STANDARD

E' fornita nella versione standard con la struttura di colore Bianco o Silver a scelta.

FORNITO NELLA VERSIONE STANDARD



The upholstery comprises 5 separate padded sections fully detachable for easy cleaning and disinfection, made of high density undeformable foam and the cover is a bi-elastic, abrasion-resistant, flame retardant and antimicrobial medical grade Skai available in 46 different colours and textures.

PROVIDED IN THE STANDARD VERSION

La tapisserie comprend 5 sections rembourrées entièrement détachables pour faciliter le nettoyage et la désinfection. Réalisée en mousse indéformable de haute densité et une couverture en Skai de catégorie médicale, bi-élastique, résistant à l'abrasion, ignifuge et antimicrobienne. Disponible dans plus de 50 couleurs et textures différentes.

FOURNI DANS LA VERSION STANDARD

La tappezzeria comprende 5 sezioni imbottite completamente rimovibili per una facile pulizia e disinfezione, realizzate in schiuma indeformabile ad alta densità e con un rivestimento in Skai bi-elastico, resistente all'abrasione, ignifugo e antimicrobico, disponibile in oltre 50 diversi colori.

FORNITO NELLA VERSIONE STANDARD



disinfection

EDGE E

EDGE E is operated by a wireless foot control with modern design and extremely intuitive. Easy to operate and clean, the foot control provides the Professional with an ergonomic and efficient working tool, useful to position the Patient comfortably and memorize different working or safety positions.

The foot control has 8 buttons to operate the 4 actuator and move the Chair sections; it is also provided with 2 memorizable positions buttons (M1, M2), the easy Patient Access-Exit position (M0), and the Sync button that enables leg-rest and back-rest simultaneous movement.

The foot control is also equipped with two buttons for the emergency positions of the Chair: the flat position and the Trendelenburg position. The pedal innovative visual and acoustic signals communicate all safety, memorized movements and charging activity of the chair and it's foot control.

PROVIDED IN THE STANDARD VERSION



Foot control support for back rail.

OPTIONAL

Support de la pédale sur rail en arrière du Fauteuil.

EN OPTION

Supporto pedale per rail posteriore.

OPZIONALE



MORE INFO ON PAGE 30

EDGE E est équipé d'une commande au pied sans fil avec un design moderne, aux fonctions simples et intuitives. Facile à utiliser et à désinfecter, la pédale garantit au Professionnel un outil de travail ergonomique et efficace, idéal pour positionner confortablement le patient et mémoriser différentes positions de travail ou de sécurité.

La pédale a 8 touches activant les 4 moteurs permettent le mouvement des différentes sections du fauteuil; La commande au pied est équipée de 2 touches de position mémorisées (M1, M2), de la touche mémoire "0" pour un accès et une sortie aisés du patient, et de la touche Sync qui active le mouvement simultané et synchronisé du dossier et de la jambière.

La pédale est également équipée de deux touches pour les positions d'urgence du Fauteuil: position table d'examen et position Trendelenburg.

Les signaux acoustiques / visuels innovants de la pédale communiquent les mouvements mémorisés, les dispositifs de sécurité, le rechargement de la batterie et toutes les activités du fauteuil.

FOURNI DANS LA VERSION STANDARD

EDGE E ha in dotazione un pedale wireless dal design moderno, semplice e intuitivo nelle sue funzioni. Facile da utilizzare e igienizzare, il pedale garantisce al Professionista uno strumento di lavoro ergonomico ed efficiente, utile ed immediato nel posizionare comodamente il Paziente ed in grado di memorizzare diverse posizioni di lavoro o sicurezza.

Il pedale ha 8 tasti che attivano i 4 attuatori permettendo il movimento delle diverse sezioni della Poltrona; è dotato di 2 tasti di posizione memorizzabili (M1, M2), il tasto di memoria "0" per l'accesso e l'uscita agevole del Paziente, e il tasto Sync che attiva il movimento simultaneo e sincronizzato dello schienale e del gambale.

Il pedale è dotato, inoltre, di due tasti per il richiamo delle posizioni di emergenza: la posizione a lettino e la posizione Trendelenburg.

Le innovative segnalazioni acustiche/visive del pedale comunicano movimenti memorizzati, sicurezze, ricarica della batteria e attività della Poltrona in movimento.

FORNITO NELLA VERSIONE STANDARD

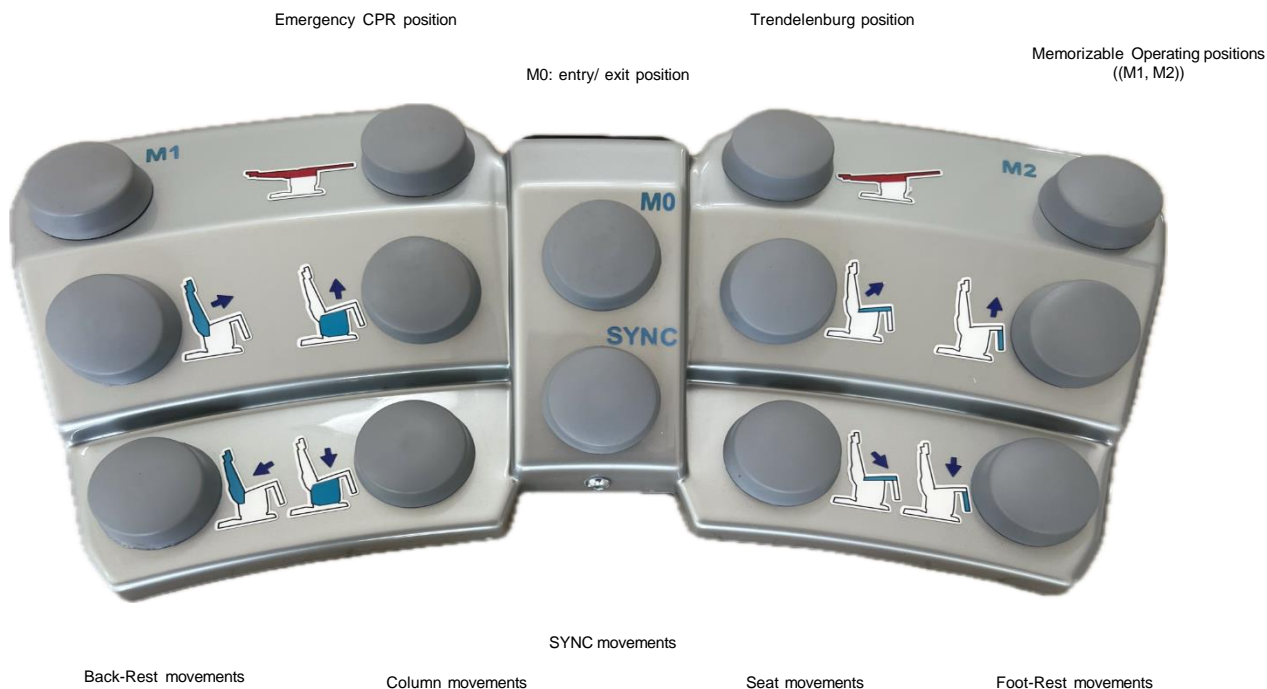



Triple Articulation Head-Rest for perfect positioning of the Patient's head in any required cranio-facial examination/surgery.

OPTIONAL

Appui-tête à triple articulation pour un positionnement parfait du Patient lors de l'examen ou le traitement chirurgicale cranio-faciale.

EN OPTION

Poggiatesta a tripla articolazione per il perfetto posizionamento del Paziente in ogni visita/chirurgia cranio-facciale.

OPZIONALE

| codice | descrizione |
|--------|-------------|
|--------|-------------|

| | |
|----------------|---|
| 9110648 | TRIPLE ARTICULATED HEAD-REST |
|----------------|---|





| codice | descrizione |
|---------|-----------------------|
| 9110604 | SCULPTURED HEAD- REST |

Sculptured Head-rest. For high precision patient positioning and head fixation; adjustable manually by articulated mechanism. Ideal for Ophthalmology, ENT, Maxillofacial Surgery, Plastic and Aesthetic Surgery.

OPTIONAL

Appui-tete Gravé. Idéal pour le positionnement précis et le confinement de la tête du patient; réglable manuellement par un joint mécanique. Idéal en Ophtalmologie, ONT, Chirurgie Maxillo-Faciale, Chirurgie Plastique / Esthétique.

EN OPTION

Poggiatesta Scolpito. Ideale per il posizionamento preciso e contenimento della testa del paziente; regolabile manualmente tramite articolazione meccanica. Ideale in Oftalmologia, Otorinolaringoiatria, Chirurgia MaxilloFacciale, Chirurgia Plastica/Estetica.

OPZIONALE



| codice | descrizione |
|---------|--------------|
| 9110606 | SIDE SUPPORT |

Side Support, it is ideal for patient stabilization and containment; it is collapsable and removable. Easy to clean and disinfect.

OPTIONAL

Soutiens latérales, idéales pour stabiliser et contenir le patient; ils sont pliables et amovibles. Installation et positionnement très simple. Ils sont faciles à nettoyer et désinfecter.

EN OPTION

Sponde Laterali, ideali per stabilizzare e contenere il Paziente; sono collassabili e amovibili. Di agevole installazione e posizionamento. Sono facili da igienizzare e disinfettare.

OPZIONALE

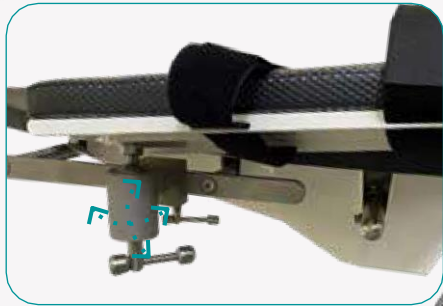

| codice | descrizione |
|---------|---------------------|
| 9110650 | KOMFORT ARM-REST |



Articulated armrests on mechanical ball joint with removable upholstery and Velcro containing belt.

OPTIONAL

Accoudoirs articulés sur rotule mécanique avec sellerie amovible et ceinture de soutien en Velcro.

EN OPTION

Braccioli articolati su snodo sferico con tappezzeria amovibile e cinghie di contenimento in velcro.

OPZIONALE



| codice | descrizione |
|---------|-----------------|
| 9110652 | TRAY SUPPORT |



Stainless steel tray support, extendable and height adjustable.

OPTIONAL

Support plateau en acier inoxydable, réglable en hauteur et extensible.

EN OPTION

Supporto per tray in acciaio inox, orientabile e allungabile in altezza.

OPZIONALE



Instruments tray.
OPTIONAL

Plan pour instruments.
EN OPTION

Piano per strumenti.
OPZIONALE



Paper Roll Support, adjustable for different roll sizes.
OPTIONAL

Support rouleau papier, réglable en fonction de différentes tailles de rouleau requises.
EN OPTION

Supporto Rotolo Carta, regolabile per dimensioni diverse del rotolo richiesto.
OPZIONALE



| codice | descrizione |
|---------|-----------------------|
| 9110621 | LUMBAR SUPPORT PILLOW |

Lumbar Support Pillow guarantees maximum comfort to the patient in supine position.
OPTIONAL

Coussin pour le soutien lombaire, idéal pour le maximum du confort du patient en décubitus dorsal.
EN OPTION

Cuscino Supporto Lombare per il massimo comfort del Paziente in posizione supina.
OPZIONALE



| codice | descrizione |
|---------|---------------------------|
| 9110610 | HALF ROUND BOLSTER PILLOW |



| codice | descrizione |
|---------|---------------------------|
| 9110611 | FULL ROUND BOLSTER PILLOW |

Half Round Bolster Pillow.
OPTIONAL

Coussin de support semi-circulaire.
EN OPTION

Cuscino di Supporto semi-circolare.
OPZIONALE

Full Round Bolster Pillow.
OPTIONAL

Coussin de support circulaire.
EN OPTION

Cuscino di Supporto circolare.
OPZIONALE

| codice | descrizione |
|---------|-------------------|
| 9110618 | FORE-ARMS SUPPORT |



Fore-Arms Support. The height-adjustable micro-surgery arm support, with its horse-shoe shape perfectly fits the head-rest region, providing maximum comfort to the Surgeon. It is adjustable in height and orientation, it is padded for maximum comfort to the fore-arms and guarantees ideal ergonomics during the procedures.

OPTIONAL

Support avant-bras. Le support de bras pour micro-chirurgie réglable en hauteur, avec sa forme en fer à cheval, s'adapte parfaitement à la région de l'appui-tête, offrant un confort maximal au chirurgien. Il est réglable en hauteur et en orientation, il est rembourré pour un maximum de confort à l'avant-bras et garantit une ergonomie idéale pendant les procédures.

EN OPTION

Supporto degli avambracci. Il supporto del braccio per microchirurgia, regolabile in altezza, con la sua forma a ferro di cavallo, si adatta perfettamente alla regione del poggiatesta, offrendo il massimo comfort al chirurgo. È regolabile in altezza e orientamento, è imbottito per il massimo comfort agli avambracci e garantisce un'ergonomia ideale durante le procedure.



| codice | descrizione |
|---------|--------------------------|
| 9110624 | PROCEDURE STABILITY POLE |

Maxillofacial/ Ophthalmology/ Oral Procedure stability poles

OPTIONAL

Colonne de stabilisation pour traitements Maxillo-faciaux/ Ophthalmologie / Orales
EN OPTION

Asta fissaggio schienale per Chirurgia Maxillofaciale/ Oftalmologia/ Orale

OPZIONALE

| codice | descrizione |
|---------|---|
| 9110636 | FLEXIBLE DRAPE SUPPORT WITH OXYGEN CONNECTION |



Flexible Surgical Drape Support with Oxygen Connection and Clamp Included
OPTIONAL

Support flexible pour Champs opératoires avec Diffuseur d'oxygène et Bloc de fixation inclus
EN OPTION

Supporto Flessibile Telo Chirurgico con Diffusore Ossigeno con Blocchetto Fissaggio Incluso
OPZIONALE



| codice | descrizione |
|---------|------------------------|
| 9110642 | FLEXIBLE DRAPE SUPPORT |



Flexible Surgical Drape Support with Clamp Included
OPTIONAL

Support flexible pour Champs opératoires avec Bloc de fixation inclus
EN OPTION

Supporto Flessibile Telo Chirurgico con Blocchetto Fissaggio Incluso
OPZIONALE





| codice | descrizione |
|---------|-------------|
| 9110633 | BATTERY KIT |

Battery kit including two batteries (capacity 5 Ah), with capacity indicator and recharger, allowing to operate the Chair without electrical supply connection. Replacing the battery with the spare one provided is very simple.

OPTIONAL

Kit de batterie comprenant deux batteries (capacité 5 Ah), avec indicateur de capacité et rechargeur, permettant de gérer le Fauteuil sans connexion électrique. Le remplacement de la batterie par celle de rechange fournie est très simple.

EN OPTION

Kit batterie costituito da coppia di batterie (capacità 5 Ah), con indicatore di capacità, e con carica batterie. Consente di operare con la Poltrona senza collegamento alla rete elettrica. Facilità di sostituzione della batteria con quella di scorta.

OPZIONALE



| codice | descrizione |
|---------|-----------------|
| 9110634 | BACK UP BATTERY |

Back up battery with 2Ah capacity allowing to operate the Chair in the event of a temporary power outage.

OPTIONAL

Batterie avec système back up et capacité de 2Ah permettant de gérer le Fauteuil en cas de coupure de courant temporaire.

EN OPTION

Batteria back up con capacità di 2Ah. Consente di movimentare la Poltrona in caso di interruzione momentanea della corrente elettrica.

OPZIONALE





| codice | descrizione |
|---------|--------------|
| 9110630 | HAND CONTROL |

The Hand Control enables the required positioning of the Patient, by activating the linear actuators that control the position of each independent section (lifting column, seat, back-rest and foot-rest).

OPTIONAL

Le clavier de commande manuelle permet le positionnement souhaité du Patient, en activant les actionneurs linéaires qui contrôlent le mouvement de chaque section indépendante (colonne télescopique, assise, dossier et jambière).

EN OPTION

La Tastiera permette di selezionare le posizioni di lavoro richieste, attivando la movimentazione degli attuatori elettrici che regolano il posizionamento delle sezioni indipendenti (sollevamento, seduta, schienale e gambale).

OPZIONALE



| codice | descrizione |
|----------|---|
| 9110631 | RACK FOR MEDICAL ACCESSORIES (white structure) |
| 9110631S | RACK FOR MEDICAL ACCESSORIES (silver structure) |

Edge accessories rack inox.

OPTIONAL

Grille porte- accessoires Edge en inox.

EN OPTION

Carrello porta- accessori Edge in inox.

OPZIONALE

DIMENSIONS AND TECHNICAL SHEETS
DIMENSIONS ET FICHES TECHNIQUES
DIMENSIONI E DATI TECNICI

| | |
|---|-------------------------|
| Supply <i>Alimentation</i> Alimentazione | 110- 230 V 50- 60 Hz |
| Operating voltage <i>Voltage</i> Tensione di rete | 24 V |
| Absorption <i>Absorption</i> Assorbimento | 350 W |
| Maximum load <i>Capacité maximum</i> Capacità di carico | 325 Kg |

| | |
|--|--------|
| Maximum load on foot-rest <i>Capacité maximum sur jambière</i> Capacità di carico sul gambaie | 85 Kg |
| Maximum load on arm-rest <i>Capacité maximum sur accoudoir</i> Capacità di carico sul bracciolo | 75 Kg |
| Maximum load on back-rest <i>Capacité maximum sur dossier</i> Capacità di carico sullo schienale | 75 Kg |
| Weight of the chair <i>Poids du fauteill</i> Peso della poltrona | 140 Kg |

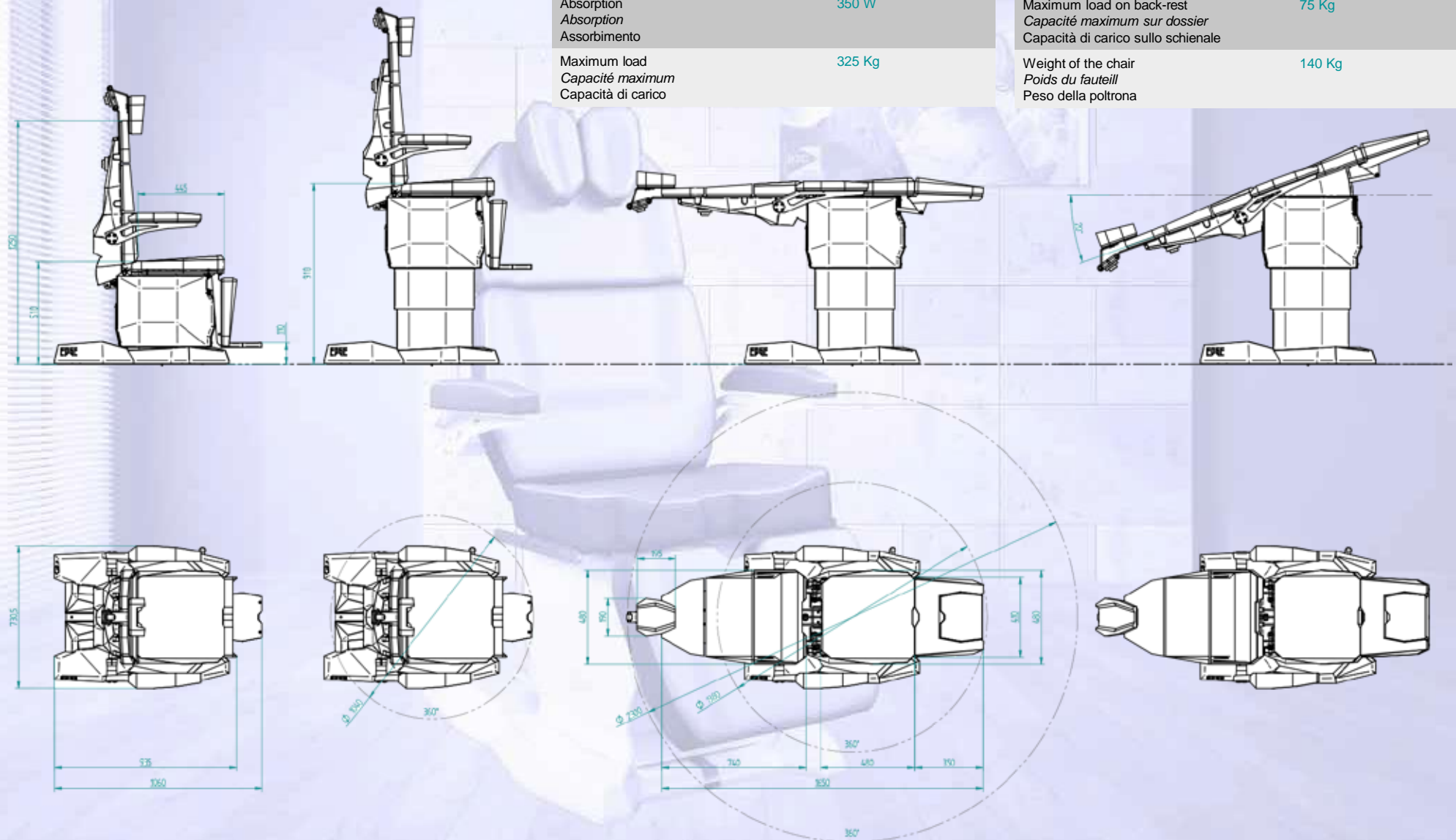

HP Gel - SA

Surgeon Stool

STOOLS - SIEGE OPERATEUR - SEGGIOLINI

Height adjustable back-rest in differentiated density visco-elastic foam.
Dossier en mousse visco-élastique à densité différenciée, réglable en hauteur.
 Schienale in schiuma visco-elastica a densità differenziata, regolabile in altezza.

Height adjustable arm-rest 360° swivel with stainless steel structure. Removable upholstery.
Accoudoir réglable en hauteur et pivotant à 360° avec structure en acier inoxydable. Rembourrage amovible.
 Bracciolo regolabile in altezza e orientabile a 360° con struttura in acciaio inox. Tappezzeria amovibile.

Seat in differentiated density visco-elastic foam with memory effect (Memory foam).
Assise en mousse visco-élastique à densité différenciée avec effet mémoire (mousse Memory).
 Seduta in schiuma visco-elastica a densità differenziata con effetto memoria (Memory foam).

Adjustable height with gas spring by a stainless steel foot control.
Hauteur réglable avec vérin à gaz actionné par la pédale de commande en acier inoxydable.
 Altezza regolabile con molla a gas tramite comando a piede in acciaio inox.

Self-braking and anti-trace wheels. Two wheels equipped with brake locks.
Roues auto-freinées et anti-traces. Deux roues équipées avec blocage à frein.
 Ruote auto-frenanti e anti-traccia. Due ruote con blocco a freno.

Doctor stool with anatomical seat. Adjustable height of the backrest. Inclination angle of the backrest is adjustable in a fixed position or can dynamically support the back muscles. Control lever for all adjustments. Base in chromed steel. Seat height adjustable by gas spring. High quality skay coating.

OPTIONAL

Siège opérateur avec assise anatomique. Hauteur du dossier réglable. L'angle d'inclinaison du dossier est réglable dans une position fixe ou peut soutenir dynamiquement les muscles du dos. Réglages par levier. Base en acier chromé. Hauteur de l'assise réglable par vérin à gaz. Revêtement en skay de haute qualité.

EN OPTION

Sedia operatore con seduta anatomica. Altezza dello schienale regolabile. L'angolo di inclinazione dello schienale è regolabile in una posizione fissa o può supportare dinamicamente i muscoli della schiena. Leva di comando per tutte le regolazioni. Base in acciaio cromato. Altezza del sedile regolabile tramite molla a gas. Rivestimento in skay di alta qualità

OPZIONALE



80 colours available

| codice | descrizione |
|---------|--------------------------------------|
| 9120504 | HP GEL - SA (without foot-rest) |
| 9120510 | HP GEL - SA (with foot-rest) |
| 9120505 | HP GEL - SA HIGH (without foot-rest) |
| 9120511 | HP GEL - SA HIGH (with foot-rest) |

HP Gel - SA Surgeon Stool

STOOLS - SIEGE OPERATEUR - SEGGIOLINI



HL Gel - SA

Surgeon Stool

STOOLS - SIEGE OPERATEUR - SEGGIOLINI

Height adjustable back-rest in differentiated density visco-elastic foam.
Dossier en mousse visco-élastique à densité différenciée, réglable en hauteur.
 Schienale in schiuma visco-elastica a densità differenziata, regolabile in altezza.

Height adjustable arm-rest 360° swivel with stainless steel structure. Removable upholstery.
Accoudoir réglable en hauteur et pivotant à 360° avec structure en acier inoxydable. Rembourrage amovible.
 Bracciolo regolabile in altezza e orientabile a 360° con struttura in acciaio inox. Tappezzeria amovibile.

Seat in differentiated density visco-elastic foam with memory effect (Memory foam).
Assise en mousse visco-élastique à densité différenciée avec effet mémoire (mousse Memory).
 Seduta in schiuma visco-elastica a densità differenziata con effetto memoria (Memory foam).

Adjustable height with gas spring by a stainless steel foot control.
Hauteur réglable avec vérin à gaz actionné par la pédale de commande en acier inoxydable.
 Altezza regolabile con molla a gas tramite comando a piede in acciaio inox.

Self-braking and anti-trace wheels. Two wheels equipped with brake locks.
Roues auto-freinées et anti-traces. Deux roues équipées avec blocage à frein.
 Ruote auto-frenanti e anti-traccia. Due ruote con blocco a freno.

Doctor stool with anatomical seat. Adjustable height of the backrest. Inclination angle of the backrest is adjustable in a fixed position or can dynamically support the back muscles. Control lever for all adjustments. Base in chromed steel. Seat height adjustable by gas spring. High quality skay coating.

OPTIONAL

Siège opérateur avec assise anatomique. Hauteur du dossier réglable. L'angle d'inclinaison du dossier est réglable dans une position fixe ou peut soutenir dynamiquement les muscles du dos. Réglages par levier. Base en acier chromé. Hauteur de l'assise réglable par vérin à gaz. Revêtement en skay de haute qualité.

EN OPTION

Sedia operatore con seduta anatomica. Altezza dello schienale regolabile. L'angolo di inclinazione dello schienale è regolabile in una posizione fissa o può supportare dinamicamente i muscoli della schiena. Leva di comando per tutte le regolazioni. Base in acciaio cromato. Altezza del sedile regolabile tramite molla a gas. Rivestimento in skay di alta qualità

OPZIONALE



80 colours available

| codice | descrizione |
|---------|--------------------------------------|
| 9120512 | HL GEL - SA (without foot-rest) |
| 9120513 | HL GEL - SA (with foot-rest) |
| 9120514 | HL GEL - SA HIGH (without foot-rest) |
| 9120515 | HL GEL - SA HIGH (with foot-rest) |

HL Gel - SA

Surgeon Stool

STOOLS - SIEGE OPERATEUR - SEGGIOLINI



HP Gel - S

Surgeon Stool

STOOLS - SIEGE OPERATEUR - SEGGIOLINI

Height adjustable back-rest in high resistance polyurethane.
Dossier en polyuréthane de haute résistance, réglable en hauteur.
Schienale in Poliuretano ad alta resistenza, regolabile in altezza.

Height adjustable arm-rest 360° swivel with stainless steel structure. Removable upholstery.
Accoudoir réglable en hauteur et pivotant à 360° avec structure en acier inoxydable. Rembourrage amovible.
Bracciolo regolabile in altezza e orientabile a 360° con struttura in acciaio inox. Tappezzeria amovibile.

Seat in differentiated density visco-elastic foam with memory effect (Memory foam).
Assise en mousse visco-élastique à densité différenciée avec effet mémoire (mousse Memory).
Seduta in schiuma visco-elastica a densità differenziata con effetto memoria (Memory foam).

Adjustable height with gas spring by a stainless steel foot control.
Hauteur réglable avec vérin à gaz actionné par la pédale de commande en acier inoxydable.
Altezza regolabile con molla a gas tramite comando a piede in acciaio inox.

Self-braking and anti-trace wheels. Two wheels equipped with brake locks.
Roues auto-freinées et anti-traces. Deux roues équipées avec blocage à frein.
Ruote auto-frenanti e anti-traccia. Due ruote con blocco a freno.

The seat naturally adapts to the user's body by increasing the contact area and decreasing the pressure on it. Circular seat with visco-elastic foam in different densities and memory effect. Multifunction armrest/back rest in high resistant polyurethane. Base in steel and polished chrome. 5 self braking wheels. Adjustable height by gas piston. High quality skay cover.

OPTIONAL

Siège opérateur avec assise circulaire en mousse viscoélastique de différentes densités, avec effet mémoire. Accoudoir/ dossier multifonctionnel en polyuréthane de haute résistance. Appui-pied en acier chromé réglable en hauteur par vérin à gaz. Revêtement en skai de haute qualité.

EN OPTION

Sedia operatore con seduta circolare in schiuma viscoelastica a densità differenziata, con effetto memoria. Bracciolo/ schienale multifunzionale in poliuretano ad alta resistenza. Base in acciaio cromato. Altezza regolabile tramite molla a gas. Rivestimento con skai di alta qualità

OPZIONALE

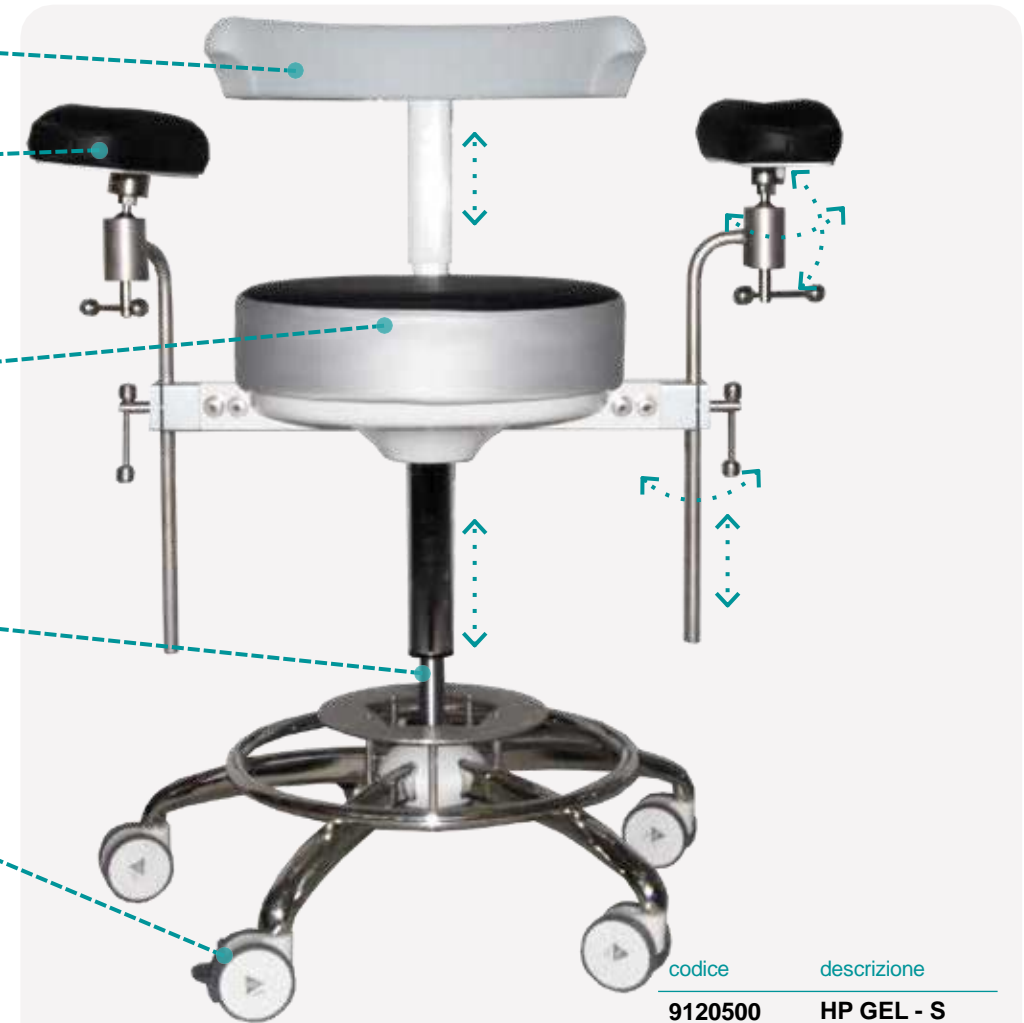

80 colours available

| codice | descrizione |
|---------|--|
| 9120500 | HP GEL - S (without foot-rest) |
| 9120506 | HP GEL - S (with foot-rest) |
| 9120502 | HP GEL - S HIGH (without foot-rest) |
| 9120507 | HP GEL - S HIGH (with foot-rest) |



80 colours available

| codice | descrizione |
|---------|--|
| 9120133 | HP GEL WITHOUT FOOT REST |
| 9120134 | HP GEL WITH FOOT REST |
| 9120136 | HP GEL WITHOUT FOOT REST - HIGH |
| 9120137 | HP GEL WITH FOOT REST - HIGH |

The seat naturally adapts to the user's body by increasing the contact area and decreasing the pressure on it. Circular seat with visco-elastic foam in different densities and memory effect. Multifunction armrest/back rest in high resistant polyurethane. Base in steel and polished chrome. 5 self braking wheels. Adjustable height by gas piston. High quality skay cover.

OPTIONAL

Siège opérateur avec assise circulaire en mousse viscoélastique de différentes densités, avec effet mémoire. Accoudoir/ dossier multifonctionnel en polyuréthane de haute résistance. Appui-pied en acier chromé réglable en hauteur par vérin à gaz. Revêtement en skai de haute qualité.

EN OPTION

Sedia operatore con seduta circolare in schiuma viscoelastica a densità differenziata, con effetto memoria. Bracciolo/ schienale multifunzionale in poliuretano ad alta resistenza. Base in acciaio cromato. Altezza regolabile tramite molla a gas. Rivestimento con skai di alta qualità

OPZIONALE

80 colours available

| codice | descrizione |
|---------|--|
| 9120430 | HL GEL WITHOUT FOOT REST |
| 9120431 | HL GEL WITH FOOT REST |
| 9120432 | HL GEL WITHOUT FOOT REST - HIGH |
| 9120433 | HL GEL WITH FOOT REST - HIGH |

Doctor stool with anatomical seat. Adjustable height of the backrest. Inclination angle of the backrest is adjustable in a fixed position or can dynamically support the back muscles. Control lever for all adjustments. Base in chromed steel. Seat height adjustable by gas spring. High quality skay coating.

OPTIONAL

Siège opérateur avec assise anatomique. Hauteur du dossier réglable. L'angle d'inclinaison du dossier est réglable dans une position fixe ou peut soutenir dynamiquement les muscles du dos. Réglages par levier. Base en acier chromé. Hauteur de l'assise réglable par vérin à gaz. Revêtement en skay de haute qualité.

EN OPTION

Sedia operatore con seduta anatomica. Altezza dello schienale regolabile. L'angolo di inclinazione dello schienale è regolabile in una posizione fissa o può supportare dinamicamente i muscoli della schiena. Leva di comando per tutte le regolazioni. Base in acciaio cromato. Altezza del sedile regolabile tramite molla a gas. Rivestimento in skay di alta qualità

OPZIONALE

EDGE SURGICAL SOLUTIONS develops and manufactures cabinets and furniture for: Ambulatory Surgery Center, Sterilisation Room, Outpatient Room and Front Office. The EDGE SURGICAL SOLUTIONS Furniture Project is paramount thanks to its innovative constructive and installation solutions that allow for an easier operating activity in the room, speed up the picking of needed instruments and material, guarantee the use of single modules as workstations during the procedures reducing obstacles and inefficiencies while allowing for a faster and easier disinfection of the operating area at the end of the activity when all modules can be stored back in the Corian® Garage. It's a space saving, clean and elegant setup that can be adapted to any room size.

Le site de production de EDGE SURGICAL SOLUTIONS développe et fabrique une gamme de mobilier sur-mesure pour: Ambulatoire de Chirurgie, Salle de stérilisation, Ambulatoire de Visite et Front Office. Le Projet Mobilier de EDGE SURGICAL SOLUTIONS se caractérise par une solution innovante de conception et d'installation à l'intérieur du Cabinet Médical, qui facilite l'ensemble des activités, comme les opérations de picking, permettant d'utiliser chaque modules comme desserte à outils en proximité de la zone d'activité et réduisant l'encombrement lors des interventions, tout en garantissant une désinfection parfaite et rapide. Une fois la journée de travail terminée, les meubles peuvent être facilement stockés à l'intérieur du garage réalisé entièrement en Corian®, facilitant les opérations de désinfection de la pièce, car l'encombrement étant réduit au minimum.

EDGE SURGICAL SOLUTIONS Progetta e Realizza nei suoi Stabilimenti Arredi su Misura per: Ambulatorio Chirurgico, Sala di Sterilizzazione, Ambulatorio Visita e Front Office. Il Progetto Arredi di EDGE SURGICAL SOLUTIONS è caratterizzato da un'innovativa soluzione costruttiva e di installazione che agevola l'attività dell'operatore in sala, facilita le operazioni di picking, permette di utilizzare i moduli come servomobili vicini alla zona operativa riducendo gli ingombri e le inefficienze durante gli interventi e garantisce una perfetta e veloce disinfezione e alla fine della giornata di lavoro possono essere facilmente riposti all'interno del garage interamente realizzato in Corian® agevolando le operazioni di disinfezione della sala riducendo al minimo gli ingombri.



EDGE SURGICAL SOLUTIONS cabinets are entirely built in metal sheet, riveted and painted with epoxy powder, the drawers modules are independent and mobile thanks to the 4 medical grade castors with 2 front brakes and no-mark rubber; the drawers are finished with metal front panels, different dimensions and colours at choice, push-pull opening/closing system and handles/free for a better and easier disinfection. The Sink is built in the Corian® working top and it guarantees perfect disinfection. State of the art design, elegant and high quality material, perfect ergonomics and absolute infection control define this EDGE SURGICAL SOLUTIONS unique project as a benchmark in Medical Furniture.

Les meubles EDGE SURGICAL SOLUTIONS sont entièrement fabriqués en acier riveté et peints à poudres époxy. Les éléments à tiroirs sont tous indépendants et mobiles, grâce à 4 roues anti-marques de qualité médicale équipées de deux freins à l'avant, d'une série de tiroirs de différentes tailles au choix et avec un système d'ouverture/fermeture Push-Pull. Les façades sont en acier peintes en différentes couleurs et sans poignées afin de garantir une parfaite désinfection. L'évier en Corian® s'intègre parfaitement au plan de travail, également réalisé en Corian®.

Un design de pointe, des matériaux élégants et de haute qualité, une ergonomie parfaite et une parfaite désinfection rendent le Projet Mobilier de EDGE SURGICAL SOLUTIONS une référence absolue en matière de mobilier médical.

Gli arredi EDGE SURGICAL SOLUTIONS sono interamente costruiti in lamiera di acciaio rivettata e verniciata con polveri epossidiche, i moduli cassetteria sono tutti indipendenti e mobili grazie alle 4 ruote medical-grade e anti-mark, dotate di due freni anteriori, cassetti di varie dimensioni a scelta e con sistema push-pull, pannelli frontali in lamiera di acciaio verniciati in diversi colori e senza maniglia per una più facile disinfezione, il lavello in Corian® è perfettamente integrato nel piano lavoro anch'esso interamente realizzato in Corian®. Una soluzione elegante, funzionale ed ergonomica unica sul mercato.





Garage Structure in steel and completely covered in Corian® to house the mobile modules. Splash-proof Corian® worktop guarantees easy cleaning and disinfection and long durability.

Structure du garage en Corian® (avec structure en acier) pour loger les meubles. Plan de travail en Corian® anti-éclaboussures garantit un nettoyage et une désinfection faciles et une longue durabilité.

Struttura a garage in Corian® (con rinforzo in acciaio) per ospitare i servomobili. Piano in Corian® con anti-splash, garantisce una facile pulizia e disinfezione e una grande durata nel tempo.



Drawers with push-pull system with stabilizer bar. Internal abs instruments trays for perfect disinfection and perfect storage.

Tiroirs avec système push pull avec barre stabilisatrice. Bac en plastique interne pour un nettoyage facile et une bonne organisation du rangement.

Cassetti con sistema di guide push pull con barra stabilizzatrice. Interni cassetto in plastica per una facile pulizia e una buona organizzazione del contenuto.



Mobile Cabinet Modules, 4 medical-grade, non-marking wheels equipped with two front brakes for easy maneuverability.

Meubles sur roues. 4 roues de qualité médicale et anti-marques équipées de deux freins à l'avant, pour une maniabilité aisée.

Servomobile su ruote. 4 ruote medical-grade e anti-mark, dotate di due freni anteriori, per una facile manovrabilità.



Corian® Worktop for an easier maneuverability of the mobile modules.

Plan de travail en Corian® avec poignée intégrée pour déplacer le meuble en toute simplicité.

Piano in Corian® con maniglia integrata per movimentare il servomobile con facilità.



Sink integrated on the Corian® worktop, available in both stainless steel and Corian® in different sizes and models.

Évier intégrables au plan en Corian®, disponibles aussi bien en acier inoxydable qu'en Corian® dans différentes tailles et modèles.

Lavabi integrabili nel piano in Corian®, disponibili sia in acciaio inox che in Corian® in diverse misure e modelli.



Hanging cabinets with drawers and flaps in different sizes and wall furniture with custom-made shelves.

Casiers suspendus avec tiroirs avec chevalet de différentes tailles et meubles hauts avec étagères sur mesure.

Pensili con cassetti a ribalta di varie dimensioni e pensili con ripiani realizzati su misura.



Possibility to integrate an archive and reporting desk with Methacrylate divider from operating area.

Possibilité d'intégrer un plan d'archive et reporting. Possibilité d'équiper avec séparateurs et paravent.

Possibilità di integrare un piano per la refertazione, dotabile di separè dalla parte operativa.



Possibility of integrating a stainless steel insert on the Corian® worktop to place the hot trays taken out from the autoclave.

Possibilité d'intégrer un insert en acier au-dessus du plan de travail en Corian® où placer les plateaux chauds sortant de l'autoclave.

Possibilità di integrare nel piano in Corian® un inserto in acciaio inox per appoggiare i vassoi caldi in uscita dall'autoclave.

Example of design tailored to the Customer
Exemple de projet sur mesure pour le Client
 Esempio di progettazione su misura per il Cliente

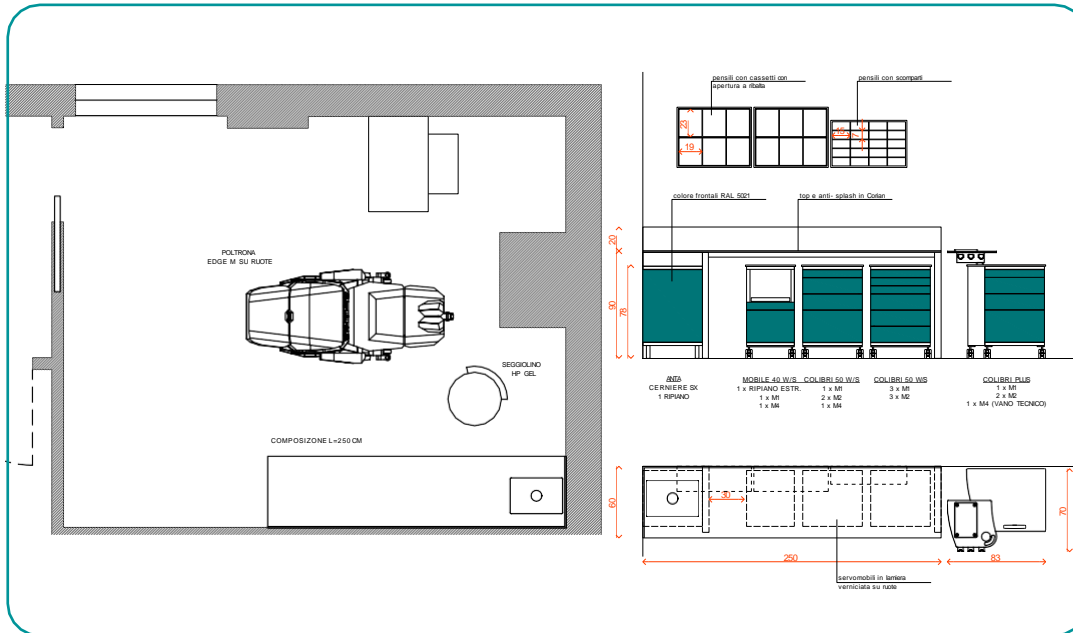

Corian® - Technical Sheet

- Corian® is a non-porous and homogeneous material, composed of approximately 1/3 acrylic resin and approximately 2/3 natural mineral substances.
- The junction points are imperceptible.
- Corian® surfaces are renewable (it can be fully restored to its original appearance by means of common detergents and an abrasive sponge).
- Corian® surfaces are hygienic.
- Corian® is an inert and non-toxic material.
- Corian® meets or exceeds emission guidelines for Volatile Organic Compounds (COV), Hazardous Air Pollutants (HAP).
- Chemical resistance. Class 1 reagents do not alter the material.

Corian® - Fiche Technique

- *Le Corian® est un matériau non poreux et homogène, composé d'environ 1/3 de résine acrylique et d'environ 2/3 de substances minérales naturelles.*
- *Les points de jonction sont imperceptibles.*
- *Les surfaces Corian® sont renouvelables (elles peuvent retrouver leur aspect d'origine à l'aide de produits communs détergents et d'une éponge abrasive).*
- *Les surfaces Corian® sont hygiéniques.*
- *Corian® est un matériau inerte et non toxique.*
- *Corian® respecte ou dépasse les directives d'émission pour les composés organiques volatils (COV), les polluants dangereux pour l'air (HAP).*
- *Résistance chimique. Les réactifs de classe 1 n'altèrent pas le matériau.*

STANDARD CONFIGURATION
CONFIGURATION STANDARD
CONFIGURAZIONE STANDARD

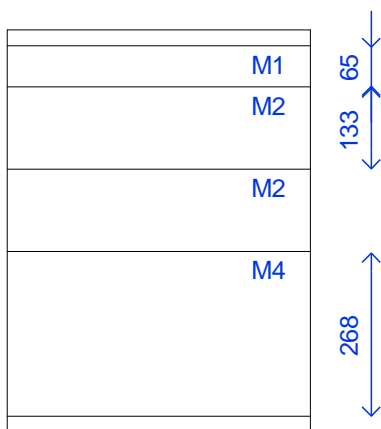

EXAMPLES OF POSSIBLE CONFIGURATIONS
EXEMPLES DE CONFIGURATIONS POSSIBLES
ESEMPI DI POSSIBILI CONFIGURAZIONI

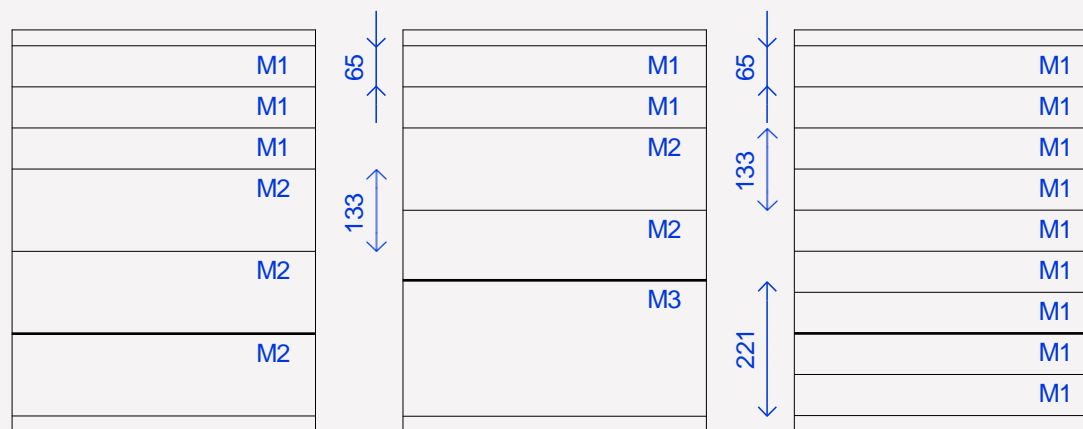

Corian® - Scheda Tecnica

- Corian® è un materiale non poroso e omogeneo, composto da circa 1/3 di resina acrilica e circa 2/3 di sostanze minerali naturali.
- Le giunture sono impercettibili.
- Le superfici in Corian® sono rinnovabili (si possono riportare all'aspetto originale con l'aiuto di normali detersivi e di una spugna abrasiva).
- Le superfici in Corian® sono igieniche.
- Corian® è un materiale inerte e non tossico.
- Corian® soddisfa o supera le linee guida delle emissioni per i composti organici volatili (COV), inquinanti pericolosi per l'aria (HAP).
- Resistenza chimica. I reattivi della classe 1 non alterano il materiale.

| codice | descrizione |
|---------|------------------------|
| 9210856 | COLIBRÌ WORKSTATION |



50 cm wide Cabinet with 4 drawers and metal fronts without handles provided with a Push-Pull opening system. Inside the drawers, storage trays for instruments. Cabinet on castors (front wheels equipped with brake) Worktop in Corian®.

OPTIONAL

Meuble de rangement de 50 cm de largeur avec 4 tiroirs et façades métalliques sans poignées équipés d'un système d'ouverture Push-Pull. A l'intérieur des tiroirs, plateaux de rangement. Meuble sur roulettes (les deux à l'avant équipés de frein) Plan de travail en Corian®.

EN OPTION

Mobile con larghezza 50 cm a 4 cassetti con frontali in metallo senza maniglie e sistema di apertura Push- Pull. All'interno dei cassetti, vassoio porta strumenti. Mobile su ruote (le due anteriori con freno) per la movimentazione e piano in Corian®.



| codice | descrizione |
|---------|--------------------------|
| 9210868 | COLIBRÌ M WORKSTATION |



Cabinet 50 cm width. Standard configuration with 4 drawers with metal fronts without handles and Push-Pull opening system. Equipped with internal instrument trays. Corian® side compartment for the equipment lodging (load capacity 8 kg). Mobile on wheels for a comfortable handling (the two front wheels are equipped with brakes). Corian® worktop.

OPTIONAL

Meuble de rangement avec largeur 50 cm. Configuration standard avec 4 tiroirs à façades métalliques sans poignées et système d'ouverture Push-Pull. Équipé de plateaux d'instruments internes. Compartiment latéral en Corian® pour accueillir l'instrumentation (capacité de charge 8 kg). Meuble sur roues (les deux roues avant sont équipées de freins). Plan de travail en Corian®.

EN OPTION

Mobile con larghezza 50 cm. Configurazione standard con 4 cassetti con frontali in metallo senza maniglie e sistema di apertura Push- Pull. All'interno dei cassetti, vassoio porta strumenti. Vano laterale sotto piano per strumentazione (capacità di carico 8 kg). Mobile su ruote (le due anteriori con freno) per la movimentazione. Piano in Corian®.

OPZIONALE

| codice | descrizione |
|---------|----------------------------|
| 9210866 | SCIROCCO 85 WORKSTATION |



Cabinet 85 cm width with 8 drawers (2 M1, 4 M2 e 2 M4) with metal fronts without handles and Push-Pull opening system. Equipped with internal instrument trays. Mobile on wheels for a comfortable handling (the two front wheels are equipped with brakes). Corian® worktop.

OPTIONAL

Meuble de rangement avec largeur 85 cm avec 8 tiroirs (2 M1, 4 M2 e 2 M4) à façades métalliques sans poignées et système d'ouverture Push-Pull. Équipé de plateaux d'instruments internes. Meuble sur roues (les deux roues avant sont équipées de freins). Plan de travail en Corian®.

EN OPTION

Mobile con larghezza 85 cm. Configurazione standard con 8 cassetti (2 M1, 4 M2 e 2 M4) con frontali in metallo senza maniglie e sistema di apertura Push- Pull. All'interno dei cassetti, vassoi porta strumenti. Mobile su ruote (le due anteriori con freno) per la movimentazione. Piano in Corian®.

OPZIONALE

| codice | descrizione |
|---------|----------------------------|
| 9210871 | SCIROCCO 90 WORKSTATION |



Cabinet 90 cm width with 6 drawers (2 drawers 40 cm wide and 6 drawers 50 cm wide) with metal fronts without handles and Push-Pull opening system. Extendable metal shelf with Soft Touch system. Equipped with internal instrument trays. Mobile on wheels for a comfortable handling (the two front wheels are equipped with brakes). Corian® worktop.

OPTIONAL

Meuble de rangement avec largeur 90 cm avec 6 tiroirs (2 tiroirs largeur 40 cm et 6 tiroirs largeur 50 cm) à façades métalliques sans poignées et système d'ouverture Push-Pull. Étagère métallique extensible avec système Soft Touch. Équipé de plateaux d'instruments internes. Meuble sur roues (les deux roues avant sont équipées de freins). Plan de travail en Corian®.

EN OPTION

Mobile con larghezza 90 cm a 6 cassetti (2 cassetti largh. 40 cm e 6 cassetti largh. 50 cm) con frontali in metallo senza maniglie e sistema di apertura Push- Pull. Piano estraibile in lamiera con guida Soft Touch. All'interno dei cassetti, vassoi porta strumenti. Mobile su ruote (le due anteriori con freno) per la movimentazione. Piano in Corian®.

OPZIONALE

UPHOLSTERY - SELLERIE - TAPPEZZERIA

EDGE SURGICAL SOLUTIONS Cool

| | | | | | |
|------|------|------|------|------|------|
| 1.06 | 1.07 | 1.08 | 1.09 | 1.10 | 1.11 |
|------|------|------|------|------|------|

EDGE SURGICAL SOLUTIONS Urban

| | | | | | |
|------|------|------|------|------|------|
| 4.01 | 4.02 | 4.03 | 4.05 | 4.06 | 4.07 |
|------|------|------|------|------|------|

EDGE SURGICAL SOLUTIONS Brio

| | | | | | |
|------|------|------|------|------|------|
| 6.07 | 6.08 | 6.09 | 6.10 | 6.11 | 6.12 |
| 6.13 | 6.14 | 6.15 | 6.16 | 6.17 | 6.18 |
| 6.19 | 6.20 | 6.21 | 6.22 | | |

EDGE SURGICAL SOLUTIONS Voyager

| | | | | | |
|------|------|------|------|------|------|
| 9.03 | 9.04 | 9.05 | 9.06 | 9.07 | 9.08 |
| 9.09 | 9.10 | 9.11 | 9.12 | 9.13 | 9.14 |
| 9.15 | 9.16 | 9.17 | 9.18 | 9.19 | 9.20 |
| 9.21 | 9.22 | 9.23 | | | |

EDGE SURGICAL SOLUTIONS Glamour

| | | | | | |
|------|------|------|------|------|------|
| 2.05 | 2.06 | 2.07 | 2.08 | 2.09 | 2.10 |
|------|------|------|------|------|------|

EDGE SURGICAL SOLUTIONS Trend

| | | | | | |
|------|------|------|------|------|------|
| 5.04 | 5.05 | 5.06 | 5.07 | 5.08 | 5.09 |
|------|------|------|------|------|------|

EDGE SURGICAL SOLUTIONS Premium

| | | | | | |
|------|------|------|------|------|------|
| 7.07 | 7.08 | 7.09 | 7.10 | 7.11 | 7.12 |
|------|------|------|------|------|------|

EDGE SURGICAL SOLUTIONS Classic

| | | | | | |
|------|------|------|------|------|------|
| 8.30 | 8.31 | 8.32 | 8.33 | 8.34 | 8.35 |
| 8.36 | 8.37 | 8.38 | 8.39 | 8.40 | 8.41 |

EDGE SURGICAL SOLUTIONS Antistatic

| |
|-------|
| 10.01 |
|-------|

UPHOLSTERY - SELLERIE - TAPPEZZERIA

EDGE SURGICAL SOLUTIONS Cool

- Fireproof**
EN 1021.1-2
IMO MSC 88/26/ADD.2 PART 8
(3.1&3.2), ISO 3795
- Bleach resistant**
- REACH Compliant**
Non toxic
Non heavy metals
No mercury
- No Bisphenol A (BPA)**
- RoHS Compliant**
- No PBTs (Persistent Bio accumulative and Toxic Chemicals)**
- No significant colour change or stiffening**
UV coef ≥ 7
- Bromine-free, no Halogenated Flame Retardants (HFRs)**
- Phtalates free**
- Abrasion resistant**
100.000 cycles
- Mildew resistant**

EDGE SURGICAL SOLUTIONS Trend

- Fireproof**
EN 1021.1-2
IMO MSC 88/26/ADD.2 PART 8
(3.1&3.2)
- Bleach resistant**
- REACH Compliant**
Non toxic
Non heavy metals
No mercury
- No Bisphenol A (BPA)**
- RoHS Compliant**
- No PBTs (Persistent Bio accumulative and Toxic Chemicals)**
- No significant colour change or stiffening**
UV coef ≥ 7
- Bromine-free, no Halogenated Flame Retardants (HFRs)**
- Phtalates free**
- Abrasion resistant**
100.000 cycles
- Fire resistant additives free**
Antimicrobial resistant additive free
Phtalates free

EDGE SURGICAL SOLUTIONS Classic

- Fireproof**
M1 (NFP 92503)
BS 5852 crib 5
B2 (DIN 4102)
EN 1021.1-2
IMO A652
FAR 25853 App F Part1 v12
CATB 117 E
CATB 133
UFAC CLASS 1
NY/NJ-Port Authority
AM 18 (NFD 60-013)
- Waterproof**
- Efficacy against bacteria (MRSA)**
- Abrasion resistant**
ISO 5470-2
150.000 cycles (12 KPa)
- Colour fastness to artificial light**
 ≥ 6
- Phtalates free**

EDGE SURGICAL SOLUTIONS Glamour

- Fireproof**
EN 1021.1-2
IMO MSC 88/26/ADD.2 PART 8
(3.1&3.2), ISO 3795
- Bleach resistant**
- REACH Compliant**
Non toxic
Non heavy metals
No mercury
- No Bisphenol A (BPA)**
- RoHS Compliant**
- No PBTs (Persistent Bio accumulative and Toxic Chemicals)**
- No significant colour change or stiffening**
UV coef ≥ 7
- Bromine-free, no Halogenated Flame Retardants (HFRs)**
- Phtalates free**
- Abrasion resistant**
100.000 cycles
- Mildew resistant**

EDGE SURGICAL SOLUTIONS Brio

- Fireproof**
BS EN 1021-1 and 2
NF P 92-503 (M2)
IMO MSC 88/26/ADD.2 PART 8
(3.1&3.2)
CATB 117-2013
UFAC CLASS 1
- Bleach resistant**
- REACH Compliant**
Non toxic
Non heavy metals
No mercury
- No Bisphenol A (BPA)**
- RoHS Compliant**
- No PBTs (Persistent Bio accumulative and Toxic Chemicals)**
- No significant colour change or stiffening**
UV coef ≥ 7
- Bromine-free, no Halogenated Flame Retardants (HFRs)**
- Phtalates free**
- Abrasion resistant**
300.000 cycles
- Anti-microbial**
Mildew resistant

EDGE SURGICAL SOLUTIONS Voyager

- Fireproof**
CL 1/ IM-M2-CRIB 5
- Waterproof**
- UV resistant, low temp. resistant**
- Mildew resistant, antibacterial and antimicrobial**
- Free of heavy metal, formaldehyde, mercury and solvents**
- Abrasion resistant**
ISO 5470-2
100.000 cycles
- Chemical resistant to acid, bases, alcohol and common solvent**

EDGE SURGICAL SOLUTIONS Urban

- Fireproof**
M2 (NFP 92503)
BS 5852 crib 5
B2 (DIN 4102)
EN 1021.1-2
IMO A652
FAR 25853 App F Part1 v12
CATB 117 E
CATB 133
UFAC CLASS 1
NY/NJ-Port Authority
AM 18 (NFD 60-013)
- Waterproof**
- Efficacy against bacteria (MRSA)**
- Abrasion resistant**
ISO 5470-2
120.000 cycles (12 KPa)
- Colour fastness to artificial light**
 ≥ 6
- Phtalates free**

EDGE SURGICAL SOLUTIONS Premium

- Fireproof**
M2 (NFP 92503)
BS 5852 crib 5
B2 (DIN 4102)
EN 1021.1-2
IMO A652
FAR 25853 App F Part1 v12
CATB 117 E
CATB 133
UFAC CLASS 1
NY/NJ-Port Authority
AM 18 (NFD 60-013)
- Waterproof**
- Efficacy against bacteria (MRSA)**
- Abrasion resistant**
ISO 5470-2
80.000 cycles (12 KPa)
- Colour fastness to artificial light**
 ≥ 6
- Phtalates free**

EDGE SURGICAL SOLUTIONS Antistatic

- Electrically conductive (antistatic) synthetic leather**
- Fireproof**
GOST
- REACH Compliant**
- Electric Resistivity**
 $10^4-10^6 \Omega$
- Phtalates free**
- No significant colour change or stiffening**
 ≥ 6

FRONT DRAWERS - TIROIRS AVANT - FRONTALI CASSETTI

| | | | | | | | | | |
|--------------------|--------------------|------------------------|--------------------|--------------------|------------------------|--------------------|--------------------|------------------------|---------------------|
| RAL 9023 (1.06) | RAL 1035 (1.07) | RAL 9023 (1.08) | RAL 8029 (1.09) | RAL 9007 (1.10) | RAL 5026 (1.11) | RAL 7042 (2.05) | RAL 7015 (2.06) | RAL 4002 (2.07) | RAL 5013 (2.08) |
| RAL 1001 (2.09) | RAL 8028 (2.10) | PANTONE 389C (4.01) | RAL 5005 (4.02) | RAL 4010 (4.03) | RAL 6034 (4.05) | RAL 3017 (4.06) | RAL 7036 (4.07) | PANTONE 391C (5.04) | RAL 8023 (5.05) |
| RAL 3031 (5.06) | RAL 1002 (5.07) | RAL 5023 (5.08) | RAL 7024 (5.09) | RAL 7021 (6.07) | RAL 5008 (6.08) | RAL 5009 (6.09) | RAL 7037 (6.10) | RAL 7036 (6.11) | RAL 8019 (6.12) |
| RAL 5000 (6.13) | RAL 5007 (6.14) | RAL 6027 (6.15) | RAL 5025 (6.16) | RAL 6000 (6.17) | RAL 3005 (6.18) | RAL 3027 (6.19) | RAL 3022 (6.20) | RAL 1032 (6.21) | RAL 1019 (6.22) |
| RAL 8017 (7.07) | RAL 7006 (7.08) | RAL 7044 (7.09) | RAL 3005 (7.10) | RAL 6003 (7.11) | RAL 5009 (7.12) | RAL 5022 (8.30) | RAL 3003 (8.31) | RAL 7040 (8.32) | RAL 9010 (8.33) |
| RAL 7036 (8.34) | RAL 8025 (8.35) | RAL 8017 (8.36) | RAL 5009 (8.37) | RAL 6034 (8.38) | PANTONE 391C (8.39) | RAL 1023 (8.40) | RAL 4010 (8.41) | RAL 8019 (9.03) | RAL 2003 (9.04) |
| RAL 3020 (9.05) | RAL 3005 (9.06) | RAL 8004 (9.07) | RAL 9006 (9.08) | RAL 5007 (9.09) | RAL 5013 (9.10) | RAL 7035 (9.11) | RAL 5023 (9.12) | RAL 5024 (9.13) | RAL 6027 (9.14) |
| RAL 7021 (9.15) | RAL 7039 (9.16) | RAL 7037 (9.17) | RAL 1013 (9.18) | RAL 1015 (9.19) | RAL 8024 (9.20) | RAL 8016 (9.21) | RAL 1036 (9.22) | RAL 4005 (9.23) | RAL 7021 (10.01) |

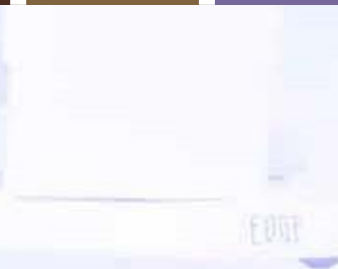

A series of horizontal dotted lines for writing notes.

A series of horizontal dotted lines for writing notes.

A series of horizontal dotted lines for writing notes.



www.edgesurgicalsolutions.com



edgesurgicalsolutions@gmail.com

CE



*“All EDGE SURGICAL SOLUTIONS Medical Equipment is designed ,
developed and manufactured in Italy”*

EDGE SURGICAL SOLUTIONS Srl

Sede Legale: Via Umberto I, 48 73039 Tricase (LE) –ITALY

Sede Operativa: S.S.275 Alessano-Lucugnano KM 17,5
73031 ALESSANO (LE) - ITALY